

MINOVA[®]



Industrial Grade Fastener Tools

CHANGZHOU CANTY ELECTRIC INDUSTRY CO., LTD



COMPANY PROFILE

Changzhou Canty Electric Industry Co., Ltd. was founded in 2002, specializing in the R&D and manufacturing of specialized tools. With production facilities in Changzhou and Zhenjiang, the company employs over 140 staff, including 15 design and R&D engineers.

Since 2013, Canty has focused on developing professional electric riveting tools, offering a pull force range from 9KN to 100KN. Our product line includes long-stroke pull-type tools (for break mandrel rivets) and precision force-controlled non-pull tools (for structural rivets). These tools are compatible with various rivets, including blind rivets, rivet nuts, and structural rivets (Heim-lok, Monobolt-style rivets, Lockbolt, KBOM rivets, and BBTAIL short-tail non-pull rivets). Backed by 24 patents in electric riveting technology, Canty delivers reliable solutions for diverse industrial needs.

Canty provides customized tooling and rivet gun nose assemblies, serving industries such as aerospace, high-speed rail, automotive, PV construction, and heavy machinery. Trusted by global partners, we combine innovation with durability to address complex riveting challenges.

KD-02X+	18V Brushless Tool for Blind Rivet / Heim-lok 3.2-6.4mm All Materials	04
KD-02XL	18V Brushless Tool for Blind Rivet / Heim-lok 3.2-6.4mm All Materials	06
KD-02HT	18V Brushless Tool for 4.8-6.4-7.8mm Multi Rivets	08
KD-0210T	18V Brushless Tool for 6.4 / 8mm Aluminum BBtail	10
KD-0230T	18V Brushless Tool for 6.4 / 8mm Steel BBtail	12
KD-0270T	36V Brushless Tool for 12mm BBtail / KBOMTAIL	14
KD-0240H	36V Brushless Tool for 8-10mm structural rivets	16
KD-0250B	36V Brushless Tool for 10mm KBOM	18
KD-02100H	36V Brushless Tool for 12mm KBOM / Lockbolt	20
KD-02G	Backpack Tool Balancer	22
KD-02S	Fastening Tool Repair Kit	24
KD-02RT	All Material Rivet Removal Tool	26



Strong & Fast

KD-02X+

18V Brushless Tool for Blind Rivet / Heim-lok

3.2-6.4mm All Materials

- Outperforms other cordless riveters with 50% faster operation.
- Features a brushless motor for superior durability and extended service life.
- Capable of riveting diverse blind rivets: aluminum, steel, and stainless steel.
- For 6.4mm structural rivets (e.g., Heim-lok or stainless steel), an 18V/4.0Ah lithium battery is recommended.
- Mandrel collectors keep job site clean.



Anti-off Nozzles



**Blind Rivet Removal Tool
(work with E-drill)**

KD-02X+

18V Brushless Tool for Blind Rivet / Heim-lok

3.2-6.4mm All Materials

Technical Data	
Pull Force	20kN (4500lbf)
Stroke	25mm (1")
Net Weight	2.4kg (5.3lbs) (with a battery)
Battery	18V / 4.0Ah
Charger	100-240V AC / 50-60Hz 21V / 2.3A
Charging Time	Approx. 100mins
Nose piece Sets	3.2 / 4.0 / 5.0 / 6.0 / 6.4mm (1/8", 5/32", 3/16", 7/32", 1/4")
Service Life	100,000 times Based on Stainless Steel Blind Rivet 6.4mm (1/4")

Product size

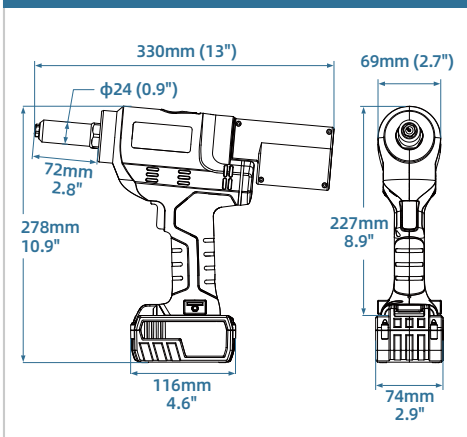

Basic Kit

- 1 KD-02X+ Rivet Gun Body
- 2 Battery*2
- 3 Charger
- 4 Nose piece Sets (3.2/4.0/5.0/6.0/6.4mm)
- 5 One Pair of Jaws
- 6 Special Wrench
- 7 Belt Clip and Wrench
- 8 Mandrel Collector
- 9 High Quality Tool Box

Riveting Data

Based on 18V/4.0Ah battery, Steel Blind Rivets

- 3.2mm (1/8"): Approx.1800 PCS
- 4.0mm (5/32"): Approx.1500 PCS
- 5.0mm (3/16"): Approx.900 PCS
- 6.0mm (7/32"): Approx.700 PCS
- 6.4mm (1/4"): Approx.600 PCS



Optional Battery Adapters



Self-push collection mandrel

Anti Clogging



KD-02XL

18V Brushless Tool for Blind Rivet / Heim-lok

3.2-6.4mm All Materials

- Specially engineered anti-loosening nose piece securely grips rivets, preventing detachment.
- Features a brushless motor for superior durability and extended service life.
- Self-push system nose ensures that sheared rivet mandrels are “automatically” pushed into the collecting bin by the following mandrel - tilting of the tool is therefore not necessary and the riveting process is accelerated.
- With an extended riveting stroke of 28mm (1.1 inch), it can accommodate 6.4x22mm (0.25"x0.86") blind rivet.



Self-collecting system,
Anti clogging sleeves



Blind Rivet Removal Tool
(work with E-drill)

KD-02XL

18V Brushless Tool for Blind Rivet / Heim-lok

3.2-6.4mm All Materials

Technical Data	
Pull Force	20kN (4500lbf)
Stroke	28mm (1.1")
Net Weight	2.4kg (5.3lbs) (with a battery)
Battery	18V / 4.0Ah
Charger	100-240V AC / 50-60Hz 21V / 2.3A
Charging Time	Approx. 100mins
Nose piece Sets	3.2 / 4.0 / 5.0 / 6.0 / 6.4mm (1/8", 5/32", 3/16", 7/32", 1/4")
Service Life	100,000 times Based on Stainless Steel Blind Rivet 6.4mm (1/4")

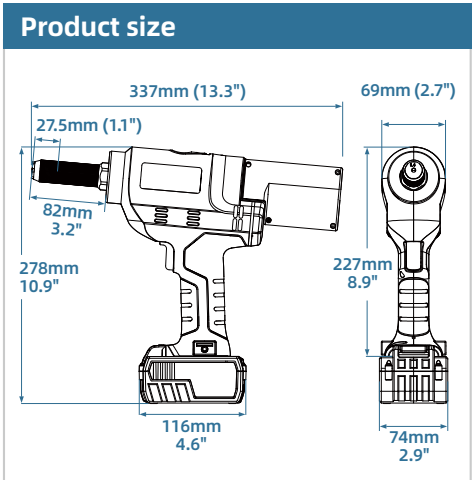

Basic Kit

- 1 KD-02XL Rivet Gun Body
- 2 Battery*2
- 3 Charger
- 4 Anti-off Nosepiece & Guide Sleeve Kit (3.2/4.0/5.0/6.0/6.4mm)
- 5 One Pair of Jaws
- 6 Special Wrench
- 7 Belt Clip and Wrench
- 8 Mandrel Collector
- 9 High Quality Tool Box

Riveting Data

Based on 18V/4.0Ah battery, Steel Blind Rivets

- 3.2mm (1/8"): Approx.2400 PCS
- 4.0mm (5/32"): Approx.2000 PCS
- 5.0mm (3/16"): Approx.1200 PCS
- 6.0mm (7/32"): Approx.900 PCS
- 6.4mm (1/4"): Approx.750 PCS



Optional Battery Adapters



KD18BS for 18V BOS Battery



KD18MT for 18V MKT Battery













KD18MW for 18V MWK Battery



KD18DW for 18V DWT Battery

Complete Truck Cab Kit Lockbolts



It is compatible with following rivets				
BLIND RIVETS	SIZE	TYPE	INSTALLS Y/N	APPLICATION
	3/16"	ALUMINUM, STEEL OR STAINLESS STEEL MAGNA LOK® BLIND RIVET	N	EXTERIOR TRIM
	1/4"	ALUMINUM, STEEL OR STAINLESS STEEL MAGNA LOK® BLIND RIVET	N	EXTERIOR TRIM
LOCKBOLTS	SIZE	TYPE	INSTALLS Y/N	APPLICATION
	3/16"	STAINLESS STEEL CL6®	Y	CHROME GRILL BOLTS
	3/16"	STEEL CL6®	Y	
	3/16"	ALUMINUM CL6®	Y	
	3/16"	ALUMINUM MAGNA-GRIP®	Y	
	3/16"	STEEL MAGNA-GRIP®	Y	TRUCK CAB BODY PANELS
	1/4"	ALUMINUM MAGNA-GRIP®	Y	
	1/4"	STEEL MAGNA-GRIP®	Y	TRUCK CAB BODY PANELS
KBOM	SIZE	TYPE	INSTALLS Y/N	APPLICATION
	1/4"	STEEL KBOM®	N	

KD-02HT

18V Brushless Tool for 4.8-6.4-7.8mm Multi Rivets

- Brushless motor technology delivers extended service life and superior durability.
- 30kN High pulling force, long stroke, enabling multifunctionality.
- Anti-drop shoulder strap securely protects the tool from fall impacts.
- Powered by an 18V/4.0Ah high-capacity lithium-ion battery.
- Specifically designed for riveting Wide Range Grip Lockbolt, Lockbolt, Heim-lok.



Hanging Hook



Battery (with Power Level)

KD-02HT

18V Brushless Tool for 4.8-6.4-7.8mm Multi Rivets

Technical Data	
Pull Force	30kN (6800lbf)
Stroke	31mm (1.2")
Net Weight	2.9kg (6.4lbs) (with a battery)
Battery	18V / 4.0Ah
Charger	100-240V AC / 50-60Hz 21V / 2.3A
Charging Time	Approx. 100mins
Fastener Capacity	Wide Range Grip: 4.8mm (3/16"), 6.4mm (1/4") Lockbolt: 4.8mm (3/16"), 6.4mm (1/4") Heim-lok: 7.8mm (5/16"), 6.4mm (1/4") KBOM: 6.4mm (1/4")
Service Life	50,000 times Based on Heim-lok Rivet 7.8mm (5/16")

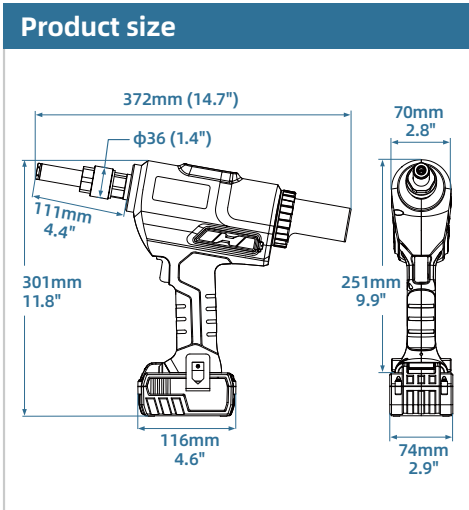

Basic Kit

- 1 KD-02HT Rivet Gun Body (exclude any nose assemblies)
- 2 Battery*2 (18V/4.0Ah)
- 3 Charger
- 4 Special Wrench
- 5 Belt Clip and Wrench
- 6 Single Shoulder Strap Assembly
- 7 High Quality Tool Box

Riveting Data

Based on 18V/4.0Ah battery, Steel Rivet

Wide Range Grip:
 4.8mm (3/16"): Approx.1100 PCS
 6.4mm (1/4"): Approx.500 PCS

Lockbolt:
 4.8mm (3/16"): Approx.1100 PCS
 6.4mm (1/4"): Approx.500 PCS

Heim-lok:
 7.8mm (5/16"): Approx.700 PCS
 6.4mm (1/4"): Approx.800 PCS

KBOM:
 6.4mm (1/4"): Approx.400 PCS



Shoulder strap included for impact protection





KD-0210T

18V Brushless Tool for 6.4 / 8mm Aluminum BBtail

- Riveting for 6.4/8.0mm aluminum BBTAIL rivets.
- Capable of adjusting pulling force according to requirements.
- Equipped with pulling force detection and alarm functions.
- Intelligently records and displays the total number of riveting operations.
- Powered by a high-efficiency 18V/5.0Ah lithium-ion battery for extended runtime.



Nose Assembly



Collar Cutter Nose Assembly

KD-0210T

18V Brushless Tool for 6.4 / 8mm Aluminum BBtail

Technical Data	
Pull Force	10kN (2300lbf)
Stroke	30mm (1.2")
Net Weight	3.1kg (6.8lbs) (with a battery)
Battery	18V / 5.0Ah
Charger	100-240V AC / 50-60Hz 21V / 8A
Charging Time	Approx. 40mins
Fastener Capacity	Aluminum BBTAIL Rivet: 6.4mm (1/4") Aluminum BBTAIL Rivet: 8.0mm (5/16")
Service Life	100,000 times Based on Aluminum BBTAIL Rivet 8.0mm (5/16")
Repeatability accuracy of Force	±1.5%
Batch accuracy of Force	±3%

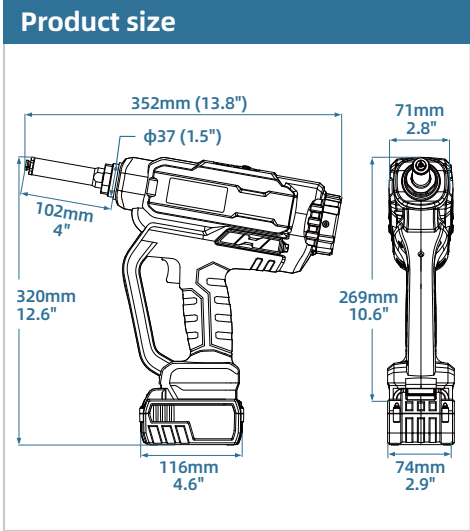

Basic Kit

- ① KD-0210T Rivet Gun Body
- ② BBTAIL 6.4mm (1/4") or BBTAIL 8.0mm (5/16") Nose Assembly
- ③ Battery*2
- ④ Charger
- ⑤ Special Wrench
- ⑥ Single Shoulder Strap Assembly
- ⑦ High Quality Tool Box

Riveting Data

Based on 18V/5.0Ah battery
Aluminum BBTAIL

BBTAIL 6.4mm (1/4"): Approx.3000 PCS

BBTAIL 8.0mm (5/16"): Approx.1800 PCS



Optional Battery Adapters



KD18BS for 18V
BOS Battery



KD18MT for 18V
MKT Battery



KD18MW for 18V
MWK Battery



KD18DW for 18V
DWT Battery



KD-0230T

18V Brushless Tool for 6.4 / 8mm Steel BBtail

- Riveting for 6.4/8.0mm steel BBTAIL rivets.
- Capable of adjusting pulling force according to requirements.
- Equipped with pulling force detection and alarm functions.
- Intelligently records and displays the total number of riveting operations.
- Powered by a high-efficiency 18V/5.0Ah lithium-ion battery for extended runtime.



Nose Assembly



Collar Cutter Nose Assembly

KD-0230T

18V Brushless Tool for 6.4 / 8mm Steel BBtail

Technical Data	
Pull Force	30kN (6800lbf)
Stroke	30mm (1.2")
Net Weight	3.1kg (6.8lbs) (with a battery)
Battery	18V / 5.0Ah
Charger	100-240V AC / 50-60Hz 21V / 8A
Charging Time	Approx. 40mins
Fastener Capacity	Steel BBTAIL Rivet: 6.4mm (1/4") Steel BBTAIL Rivet: 8.0mm (5/16")
Service Life	100,000 times Based on Steel BBTAIL Rivet 8.0mm (5/16")
Repeatability accuracy of Force	±1.5%
Batch accuracy of Force	±3%

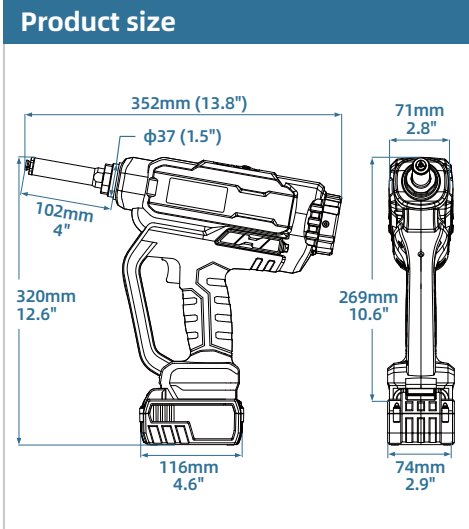

- Basic Kit**
- ① KD-0230T Rivet Gun Body
 - ② BBTAIL 6.4mm (1/4") or BBTAIL 8.0mm (5/16") Nose Assembly
 - ③ Battery*2
 - ④ Charger
 - ⑤ Special Wrench
 - ⑥ Single Shoulder Strap Assembly
 - ⑦ High Quality Tool Box

Riveting Data

Based on 18V/5.0Ah battery
Steel BBTAIL

BBTAIL 6.4mm (1/4"): Approx.1200 PCS
BBTAIL 8.0mm (5/16"): Approx.800 PCS

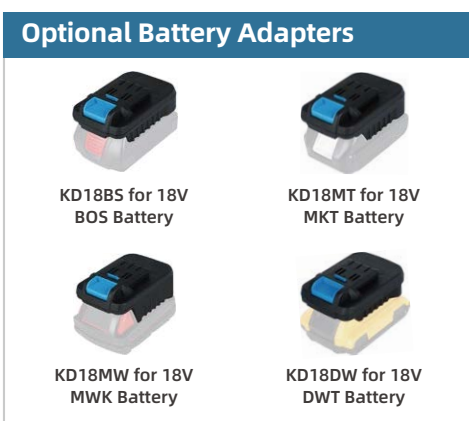



KD-0270T

36V Brushless Tool for 12mm BBtail / KBOMTAIL

- Capable of adjusting pulling force according to requirements.
- Integrated force monitoring system with visual/audible alarms for overload protection.
- Smart rivet counter automatically tracks and displays total operation count.
- Large capacity with long endurance, and compliant with non-hazardous material safety transportation requirements.
- Cutter Nose Assembly is optional.



Nose Assembly



Collar Cutter Nose Assembly

KD-0270T

36V Brushless Tool for 12mm BBtail / KBOMTAIL

Technical Data	
Pull Force	70kN (15700lbf)
Stroke	60mm (2.4")
Net Weight	6.8kg (15lbs) (with two batteries)
Battery	18V / 5.0Ah
Charger	100-240V AC / 50-60Hz 21V / 8A
Charging Time	Approx. 40mins
Fastener Capacity	BBTAIL Rivet: 12mm (1/2") KBOMTAIL:12mm (1/2")
Service Life	50,000 times Based on Steel BBTAIL Rivet 12mm (1/2")
Repeatability accuracy of Force	±1.5%
Batch accuracy of Force	±3%

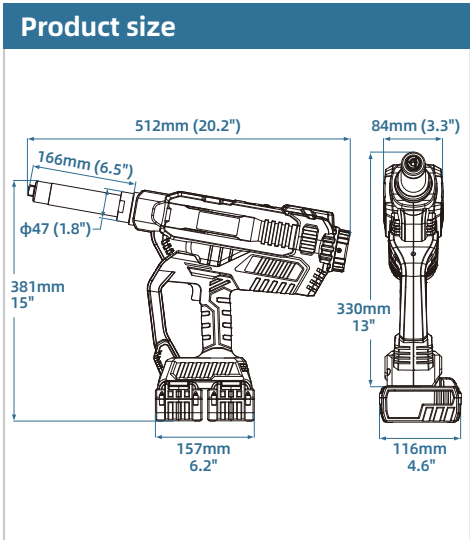

Basic Kit

- ① KD-0270T Rivet Gun Body
- ② BBTAIL 12mm (1/2") or KBOMTAIL 12mm (1/2") Nose Assembly
- ③ 18V Battery*4
- ④ Charger*1
- ⑤ Special Wrench
- ⑥ Single Shoulder Strap Assembly
- ⑦ High Quality Tool Box

Riveting Data

**Based on 18V/5.0Ah battery*2,
Steel Rivets**

BBTAIL 12mm (1/2"): Approx.300 PCS

KBOMTAIL 12mm (1/2"): Approx.300 PCS



With Backpack Tool Balancer





KD-0240H

36V Brushless Tool for 8–10mm structural rivets

- KD-0240H is specifically designed for riveting KBOM 8.0mm (5/16"), Lockbolt 8.0mm (5/16"), Lockbolt 10mm (3/8"), Monobolt-style rivets 9.8mm (3/8").
- Large capacity with long endurance, and compliant with non-hazardous material safety transportation requirements.
- Smart rivet counter automatically tracks and displays total operation count.
- Cutter Nose Assembly is optional.



Nose Assembly



Cutter Nose Assembly

KD-0240H

36V Brushless Tool for 8-10mm structural rivets

Technical Data	
Pull Force	40kN (9000lbf)
Stroke	40mm (1.6")
Net Weight	5.7kg (12.6lbs) (with two batteries)
Battery	18V / 5.0Ah
Charger	100-240V AC / 50-60Hz 21V / 8A
Charging Time	Approx. 40mins
Fastener Capacity	KBOM: 8.0mm (5/16") Lockbolt: 8.0mm (5/16"), 10mm (3/8") Monobolt-style rivets: 9.8mm (3/8")
Service Life	50,000 times Based on KBOM 8.0mm (5/16")

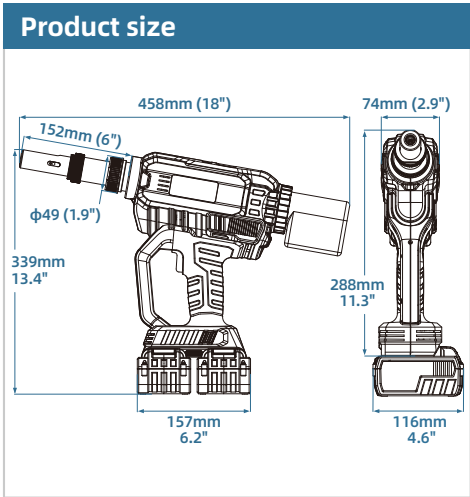

Basic Kit

- 1 KD-0240H Rivet Gun Body
- 2 KBOM 8.0mm (5/16") or Lockbolt 8.0mm (5/16") Nose Assembly
Lockbolt 10.0mm (3/8") or Monobolt-style rivets 9.8mm (3/8")
Nose Assembly
- 3 18V Battery*4
- 4 Charger*1
- 5 Special Wrench
- 6 Single Shoulder Strap Assembly
- 7 High Quality Tool Box

Riveting Data

**Based on 18V/5.0Ah battery*2,
Steel Rivets**

- KBOM 8.0mm (5/16"): Approx.900 PCS
- Lockbolt 8.0mm (5/16"): Approx.1200 PCS
- Lockbolt 10.0mm (3/8"): Approx.1000 PCS
- Monobolt-style rivets 9.8mm (3/8"):
Approx.1000 PCS



With Backpack Tool Balancer





KD-0250B

36V Brushless Tool for 10mm KBOM

- Employing a brushless motor for enhanced durability and longevity.
- Large capacity with long endurance, and compliant with non-hazardous material safety transportation requirements.
- Smart rivet counter automatically tracks and displays total operation count.
- Ergonomic handle with integrated LED worklight.
- Cutter Nose Assembly is optional.



Nose Assembly



Cutter Nose Assembly

KD-0250B

36V Brushless Tool for 10mm KBOM

Technical Data	
Pull Force	50kN (11000lbf)
Stroke	50mm (2.0")
Net Weight	7kg (15.4lbs) (with two batteries)
Battery	18V / 5.0Ah
Charger	100-240V AC / 50-60Hz 21V / 8A
Charging Time	Approx. 40mins
Fastener Capacity	KBOM 10.0mm (3/8")
Service Life	50,000 times Based on KBOM 10.0mm (3/8")

Product size

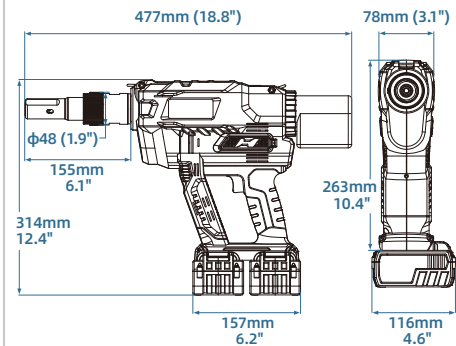

Basic Kit

- ① KD-0250B Rivet Gun Body
- ② KBOM 10.0mm (3/8") Nose Assembly
- ③ 18V Battery*4
- ④ Charger*1
- ⑤ Special Wrench
- ⑥ Single Shoulder Strap Assembly
- ⑦ High Quality Tool Box

Riveting Data

Based on 18V/5.0Ah battery*2,
Steel Rivets

KBOM 10.0mm (3/8"): Approx.850 PCS



With Backpack Tool Balancer

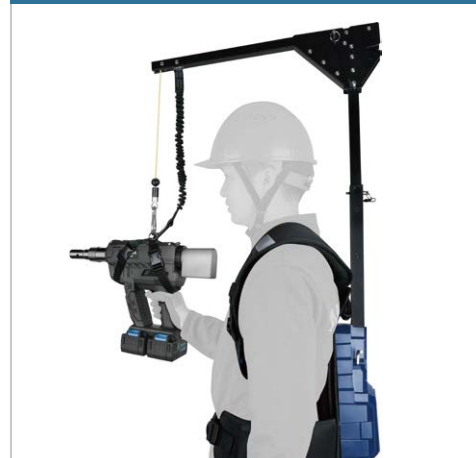



KD-02100H

36V Brushless Tool for 12mm KBOM / Lockbolt

- Brushless motor technology delivers extended service life and superior durability.
- Large capacity with long endurance, and compliant with non-hazardous material safety transportation requirements.
- Smart rivet counter automatically tracks and displays total operation count.
- Ergonomic handle with integrated LED worklight.
- Cutter Nose Assembly is optional.



Nose Assembly



Cutter Nose Assembly

KD-02100H

36V Brushless Tool for 12mm KBOM / Lockbolt

Technical Data	
Pull Force	100kN (22500lbf)
Stroke	60mm (2.4")
Net Weight	8.5kg (18.7lbs) (with two batteries)
Battery	18V / 5.0Ah
Charger	100-240V AC / 50-60Hz 21V / 8A
Charging Time	Approx. 40mins
Fastener Capacity	KBOM 12mm (1/2") Lockbolt 12mm (1/2")
Service Life	30,000 times Based on KBOM 12mm (1/2")

Product size

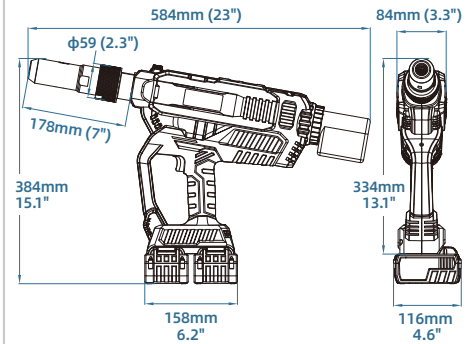

Basic Kit

- 1 KD-02100H Rivet Gun Body
- 2 KBOM 12mm (1/2") or Lockbolt 12mm (1/2") Nose Assembly
- 3 18V Battery*4
- 4 Charger*1
- 5 Single Shoulder Strap Assembly
- 6 High Quality Tool Box

Riveting Data

Based on 18V/5.0Ah battery*2,
Steel Rivets

KBOM 12mm (1/2"): Approx.450 PCS

Lockbolt 12mm (1/2"): Approx.350 PCS



With Backpack Tool Balancer

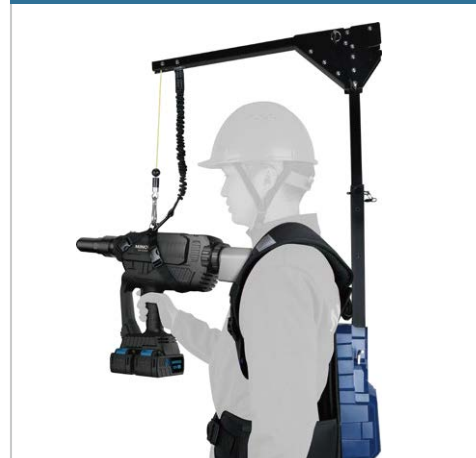



KD-02G

Backpack Tool Balancer

- Zero gravity handling - after adjusting to balances tool weight (up to 9kg) for a comfortable and weightless feel at any position (height).
- Designed for a safer jobsite - improves ergonomics to reduce fatigue, arms and shoulder strain, from repetitive and continuous hours of work.
- Helps increase productivity - makes your riveting work lightweight, easier, and more precise.
- All-day flexibility and control-makes hard to long time operating for easier, and portability on site with a foldable support arm and telescopic back support weight under 5 kg.

KD-02G

Backpack Tool Balancer

Technical Data

Product Weight	5.0kg (11lbs)
Adjustable Load Capacity	5-9kg (11-20lbs) (Different specifications may have different load capacities)
Belt Size	145cm (57")
Device Length	86 / 105 / 112 cm (34" / 41" / 44")
Service Life	1 year

Product size

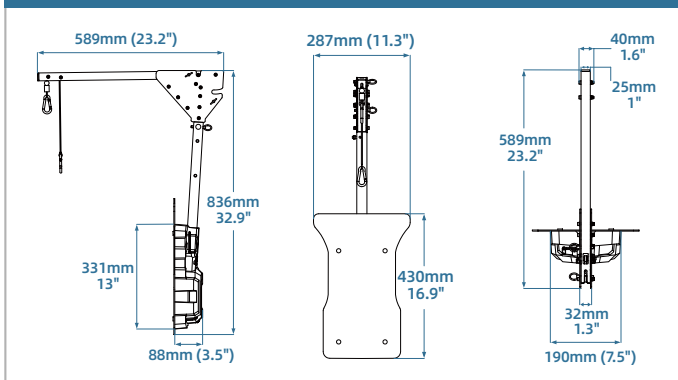

Battery Storage Bag



Basic Kit

- ① KD-02G Backpack Tool Balancer
- ② Hex Key*2
- ③ Instruction Manual
- ④ High Quality Fabric Case



Safety Rope Design, Double Security

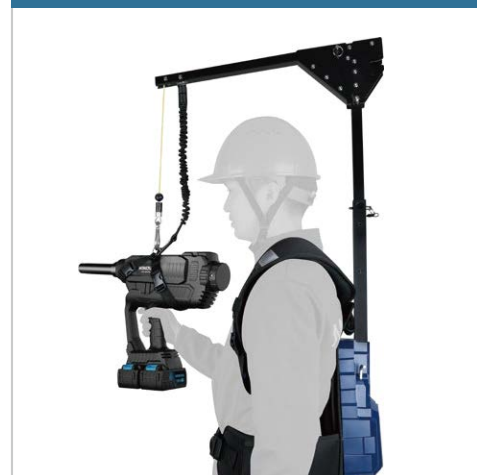

Full set of tools

Lightweight and easy to carry

Individual tool storage



KD-02S

Fastening Tool Repair Kit

- Contains a variety of tools for maintaining Minova fastening tools.
- Compatible with MINOVA fastening tool batteries.
- Covers a wide range of tasks: disassembling power tools, soldering circuit boards, replacing parts, and applying lubricating oil.

KD-02S

Fastening Tool Repair Kit



Basic Kit

- | | | |
|---------------------------|-----------------------------|---|
| ① Plastic tool box | ⑨ 638 Adhesive | ⑰ HSS Drill Bits, $\phi 3 \sim \phi 10$ |
| ② Pistol Drill | ⑩ Hex Key (Allen Wrench) | ⑱ Heat Shrink Tubing |
| ③ Heat Gun | ⑪ Slotted Screwdriver | ⑲ Adapter Plug |
| ④ Electric Soldering Iron | ⑫ Diagonal Cutters | ⑳ Long-Nose Pliers |
| ⑤ Solder Wire | ⑬ Hex Key Bits 1.5~8 | ㉑ Hammer |
| ⑥ Extension Rod | ⑭ Phillips Bits | ㉒ Grease |
| ⑦ Tweezers | ⑮ Hex Socket Bits 10mm | |
| ⑧ Adjustable Wrench | ⑯ Torx Security Bits T5~T40 | |



Fast Remove

KD-02RT

All Material Rivet Removal Tool

- The Minova Rivet Removal Tool includes drill bits for removing 3.2mm (1/8"), 4.0mm (5/32"), 5.0mm (3/16"), 6.0mm (7/32"), and 6.4mm (1/4") standard and stainless steel rivets.
- Simply attach the appropriate drill bit to your power drill, drill through the rivet head, and effortlessly remove blind rivets.
- This rivet removal tool is specifically designed for dismantling dome head, brazier head, and pan head rivets.
- This rivet removal tool allows for fast and easy rivet removal while protecting the workpiece surface from damage.
- High-cobalt drill bits offer exceptional durability and are suitable for drilling all types of materials.

KD-02RT

All Material Rivet Removal Tool

Technical Data	
Package Size(Full)	175x105x25mm (6.9"x4.1"x1.0")
Package Size(Single)	155x65x30mm (6.1"x2.6"x1.2")
G.W.(Full)	261g (0.6lbs)
G.W.(Single)	165.5g (0.4lbs)
Material	Steel & Aluminum
Size	142mm (5.6")
Drill Spec.	3.2 / 4.0 / 5.0 / 6.0 / 6.4mm (1/8", 5/32", 3/16", 7/32", 1/4")
Service Life	300-500 times based on Steel Blind Rivets

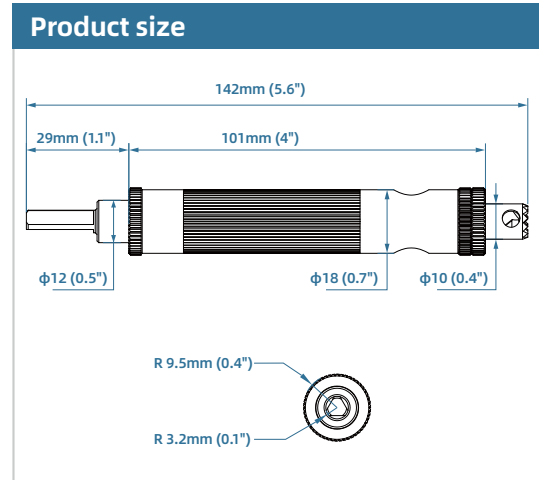

Basic Kit

- ① 1* Rivet Removal Tool 3.2mm
- ② 1* Rivet Removal Tool 4.0mm
- ③ 1* Rivet Removal Tool 5.0mm
- ④ 1* Rivet Removal Tool 6.0mm
- ⑤ 1* Rivet Removal Tool 6.4mm
- ⑥ 1* Box Packing

High Cobalt Drill Bits



Anti-slip Triangle Shaft



After removing





Industrial Grade Fastener Tools

CHANGZHOU CANTY ELECTRIC INDUSTRY CO., LTD

Add : 8# , Jianye Road , Changzhou, Jiangsu Province, China 213125

Tel : 0086 519 85962300

Fax : 0086 519 85962311

Mob: 0086 13861078275

Email : support@minovafastening.com

Web: www.minovafastening.com

The warehouse address in Germany: Steinstraße 16, 72669 Unterensingen Germany



Website

Exclusive Distributor in Spain & Portugal and & Official Repair Center for Europe.

Remaches Tudela, S.L.

Isaac Ciordia

Email: isaac@remachestudela.com

Website: www.remachestudela.com

Address: P.I. Las Labradas, C/ Cantabria 14.8 y 14.9, Tudela - 31500 Navarra , España

Phone: +34 948 827 121